

# Fitting Instruction

## MATERIALS

A	1	Cross Bar
B	2	Side Plate
D	1	Right hand sidearm
E	1	Left hand sidearm
F	4	M12 x 1.75 x 110mm Bolts ,8 Flat Washers (30mm OD) and Nyloc Nuts
G	8	M10 x 1.25 x 30mm Bolts, Lock Washers and Flat Washers (30mm OD)
H	2	M12 x 1.75 x 40mm Bolts, Nyloc Nuts and Flat Washers (30mm OD)
J	4	M12 x 1.75 x 50mm Bolts, Nyloc Nuts and Flat Washers (30mm OD)
ZC	2	M12 x 1.75 x 100mm 10.9 grade Bolts and Nyloc Nuts
ZF	1	Neck assembly
ZSB1	2	Packers

## FITTING

1. Remove rear silencer box for ease of access. Remove towing eye from left hand side and discard.
2. **Very loosely** attach Side Plates (B) and Sidearms (D & E) using Bolts (F) (G) with Flat Washers to vehicle chassis.
3. Facelift models with a flat lower section require a bumper cut as shown below – **Check by offering up crossbar (A) before cutting.**
4. Insert Cross bar (A) inside Bumper (taking care not to trap number plate wiring loom) and attach to vehicle chassis using Bolts (J) and (H) with Flat washers.
5. Bend back lower bumper tags slightly to allow fitment of neck housing.
6. Refit silencer
7. **Fully tighten all bolts ensuring crossbar is pushed up inside bumper, a minimum of 15mm clearance should be achieved between exhaust and towbar.**
8. Fit Neck assembly (ZF) with Bolts (ZC) and Packers (ZSB1), fully tighten all Bolts.

**Recommended torque settings:** Grade 8.8 bolts: M8 - 24Nm, M10 - 52 Nm, M12 - 95 Nm, M14 - 130 Nm, M16 - 200 Nm **Grade 10.9: M12 – 140Nm**, M10 – 70Nm M8- 35Nm

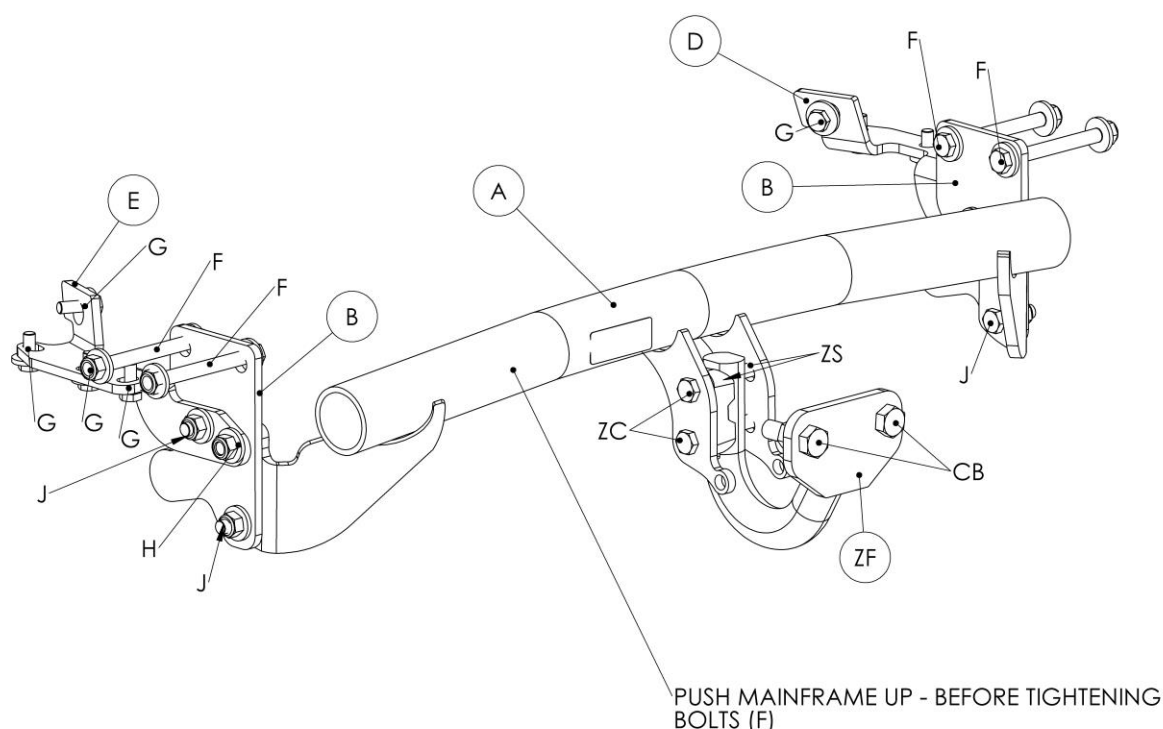

### Bumper cut pre- 2018 models:

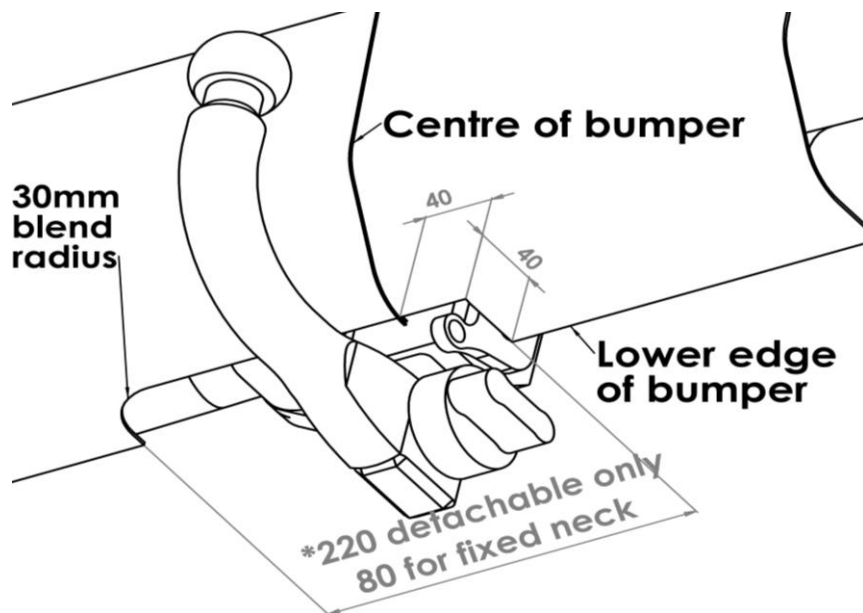

### Bumper cut post- 2018 face lift models:

