

FITTING INSTRUCTIONS

Ford Mondeo Hatch/Saloon

Incl. Titanium X Sport (Bumper cut req'd)

July 2007-

TFO160DT TFO160 101116

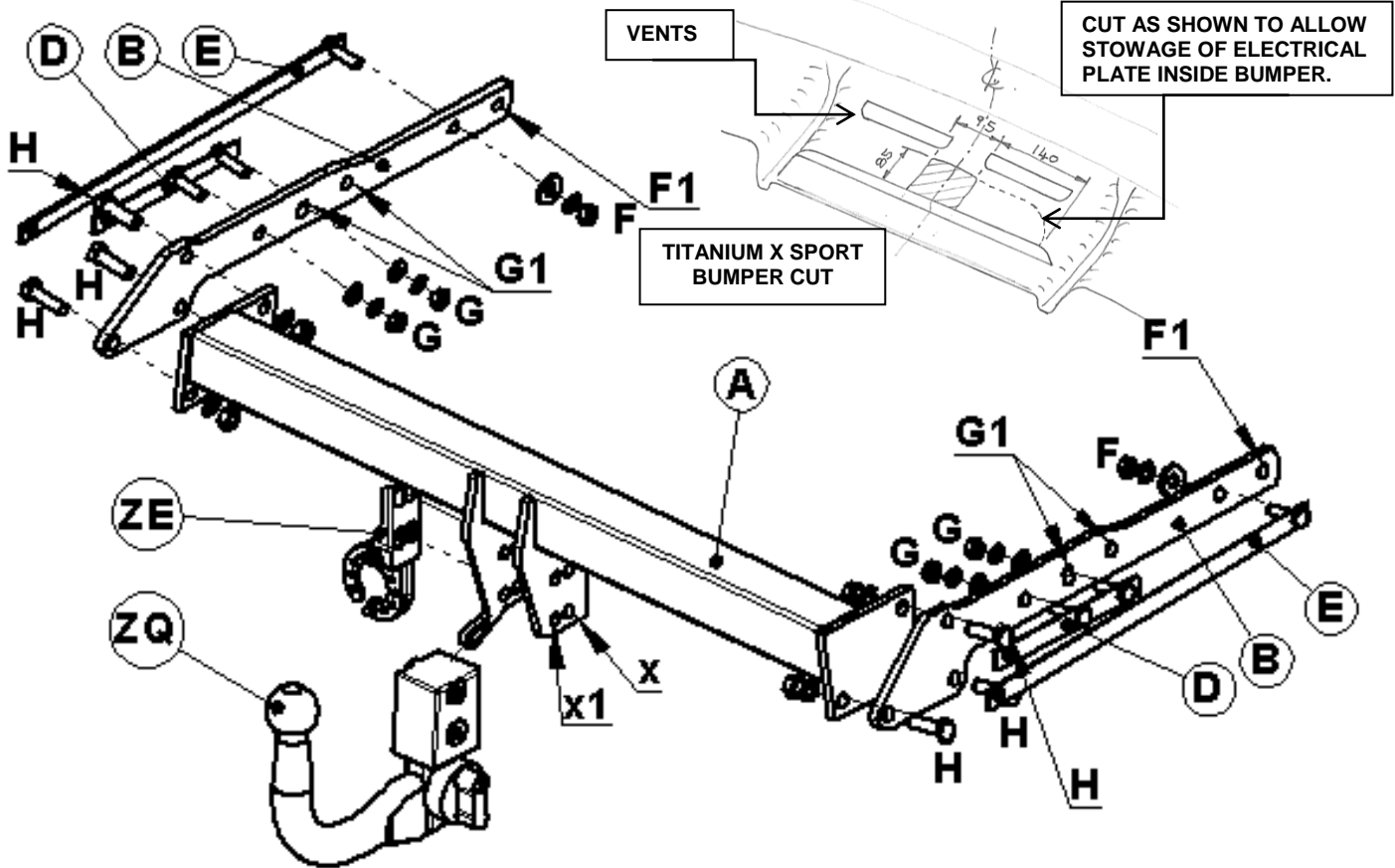

MATERIALS

A	1	Cross Bar
B	2	Bracket
D	2	Bolt Straps
E	2	Long Bolt Straps
F	2	M10 x 1.5 pitch Nuts, Lock Washers, Flat Washers (OD 30mm)
G	4	M10 x 1.5 pitch Nuts, Lock Washers, Flat Washers (OD 30mm)
H	6	M12 x 40 x 1.75 pitch Bolts, Nuts, Lock Washers
ZE	1	Retractable Electrical Plate

FITTING

Titanium X Sport Models Only

This particular model has a 'venturi-style' rear bumper, which requires a visible cut to be made. Please see below for the cut details:

1. Remove bumper. (3 screws in wheel arch, 2 screws on top edge, 2 plastic screws on bottom edge, pull tips away from body clips.)
2. Remove steel bumper beam to expose openings into chassis rails.
3. Lower the rearmost exhaust silencer(s) and remove the exhaust heat shield(s).
4. Insert Brackets (B) into chassis rails and loosely secure with Bolt Straps (D) and fasteners (G) Note: Use holes shown for Hatchback (5 door) vehicles and holes (G1) for Saloon (4 door) vehicles.
5. Assemble Long Bolt Straps (E) through Brackets (B) and secure using fasteners (F). Note: Use holes shown for Hatchback (5 door) vehicles and holes (F1) for Saloon (4 door) vehicles.
6. Assemble Crossbar (A) to Brackets (B) using fasteners (H).
7. Assemble the chosen Tow Ball Neck variant to holes (X) and Retractable Electrical Plate (ZE) to Cross Bar (A) using separate fitting instructions. Note: Use holes (X1) for Titanium X Sport models only.
8. Fully Tighten all Fasteners
9. Refit the exhaust heat shield and silencer.

Note: This towbar must be used with a Class A50-1 or A50-X towball, which dimensionally conforms to A50-1 with a 'D' and 'S' value greater than or equal to that of the towbar.

Recommended torque settings: Grade 8.8 bolts: M8 - 24Nm, M10 - 52 Nm, M12 - 80 Nm, M14 - 130 Nm, M16 - 200 Nm Grade 10.9: M12 - 120Nm, M10 - 70Nm M8- 35Nm