



# Fitting Instructions

TOWBAR KA19AU  
For Kia Cee'd for  
Feb 2007- KA19A &  
KA19AQ  
KA19AQF

## MATERIALS

A	1	Cross Bar
D	2	Angle Cleat.
E	8	M10 x 40 x 1.25 fine pitch Bolts, 2 Nuts, Lock Washers and 10 Flat Washers (25mm OD.)
Z	1	Electrical Plate (ZEP3)
BC	4	M12 Bolt Caps

### For use with either

**KA19A Flange neck option – ZF2030.** **Note:** This towbar must be used with either a Witter Towball (part number Z11) or Class A50-1 or A50-X towball dimensionally Conforming to A50-1 with a 'D' and 'S' value greater than or equal to that of the towbar.

**KA19AQ (QF) Detachable neck option – ZQ2030.** Please refer to ZQ fitting instructions for installation

## FITTING

1. **Remove any protective coating around mountings in chassis.**
2. **Estate models only-**remove left hand lower panel to reveal mounting points.
3. Loosely attach Crossbar (A) and Angle Cleats (D) to existing captive nuts in vehicle chassis using Bolts (E) with Flat Washers. Loosely attach Angle Cleats (D) to Crossbar (A) using remaining Bolts (E).
4. Loosely attach Neck option, Electrical Plate (Z) to Crossbar (A) using Bolts (F).
5. Fully tighten all bolts and fit Bolt Caps (BC) to Bolts (F).
6. **Estate models only-**offer up lower panel and mark an area where panel touches the sidearm of crossbar (A). Remove this area and refit panel.
7. Check clearance around exhaust tail pipe and adjust hanger to gain more clearance if required.

Please refer to the vehicle specification for the trailer weight and nose limits, which **must be observed**.

**Recommended torque settings:** M8 - 27Nm, M10 - 53 Nm, M12 – 139 (10.9) Nm, M14 - 150 Nm, M16 - 214 Nm

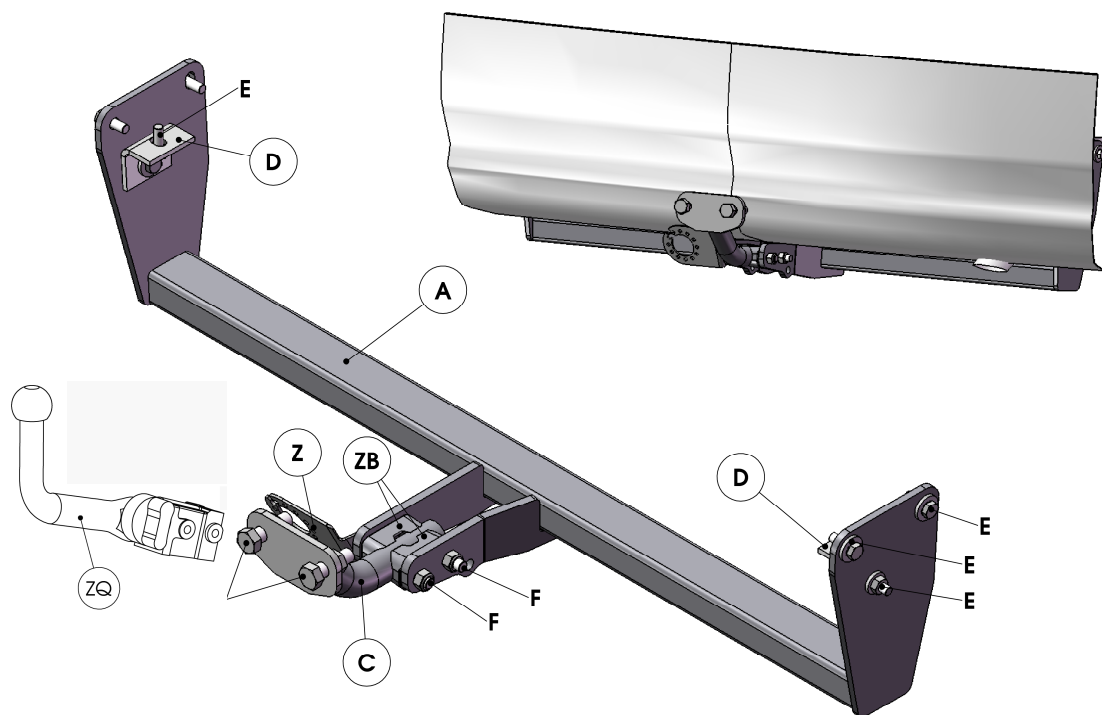

W0001KA19AU-FIT\$010802220000