



# Fitting Instructions

Tow bar for **MHE3**  
Elddis Autoquest 145

## MATERIALS

A	1	Cross Bar with European facing to 94/20/EC Class A50-1
B	2	Side Arms
C	8	M12 x 35mm x 1.75 Bolts, Nyloc Nuts and Flat Washers (40mm)
D	4	M12 x 35mm x 1.75 Bolts and Nyloc Nuts
CB	2	M16 x 60mm Coupling Bolts, Nuts, Lock Washers
Z11	1	Tow ball
Z3	1	Tow ball Boot Cover (not shown)
ZE	1	Electrical Plate (not shown)
EC	1	Electrical Kit (not shown)

## FITTING

1. Loosely attach Side Arms (B) to existing holes using fasteners (C), through the lower group of Side Arm holes typically. (Note: If a 25mm lower ball height is required mount the Side Arms using the upper group of holes)
2. Loosely attach Crossbar (A) to Side Arms (B) using fasteners (D).
3. Loosely attach Tow ball (Z11) and Electrical Plate (ZE) using fasteners (CB) and fully tighten all bolts.
4. Please refer to Electrical Kit fitting instruction to fit electrical kit.

**Note:** This tow bar must be used with either a Witter Towball (part number Z11) or Class A50-1 or A50-X towball dimensionally conforming to A50-1 with a 'D' and 'S' value greater than or equal to that of the towbar.

Please refer to the vehicle specification for the trailer weight and nose limits, which **must be observed**.

**Recommended torque settings:** M8 - 27Nm, M10 - 53 Nm, M12 - 95 Nm, M14 - 150 Nm, M16 - 214 Nm

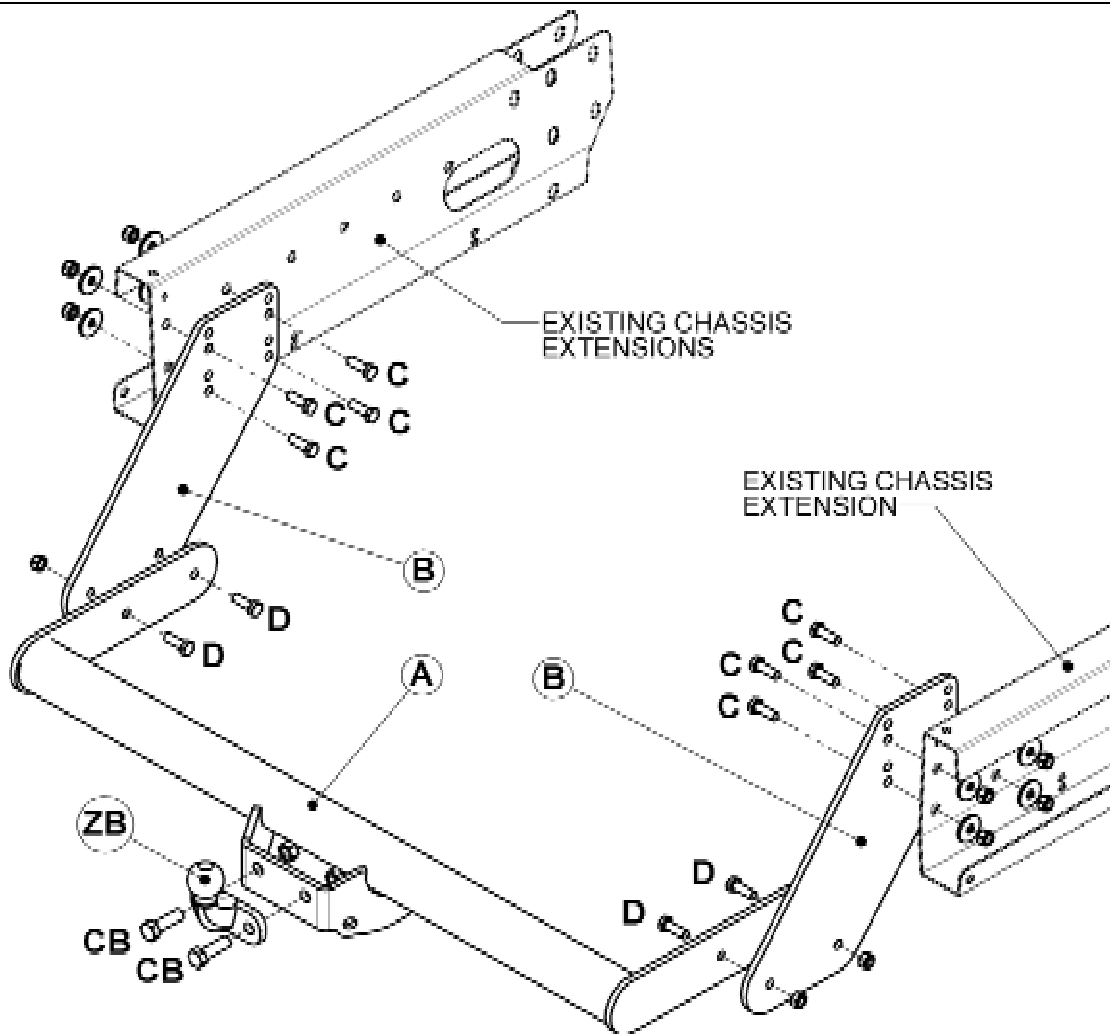

W0001MHE3-FIT\$011310100000