



Fitting Instructions

Universal TOWBAR MZ48AU

For Mazda 6

2008-

For use with 3012 series necks

MATERIALS

A	1	Cross Bar
D	2	Exhaust hanger straps
E	4	M12 x 45 x 1.75 Bolts, Lock Washers and Flat Washers (40mm O.D.)
F	2	M10 x 50 x 1.5 Bolts, Nyloc Nut and Flat Washer (30mm O.D.)
ZE	1	ZEQ4 Angle cleat
ZP	1	Z99 Flip up electrical plate kit

FITTING

1. Remove bumper - 1 screw fixing beneath light cluster (remove light cluster – 3 nuts and carefully pull backwards to release from clip at forward tip), 1 tip screw, 1 screw on wheel arch lower edge, push in clips along lower edge and estate models have 2 screws on boot shut panel. – Bumper has clips along rear panel, the bumper must be pulled backwards to release.
2. Remove rear silencer to improve access.
3. Prise off rear most exhaust hanger (s) from bumper beam, remove and discard bumper beam.
4. Insert Cross Bar (A) inside open ends of chassis. (**Note:** Cross bar will be tight until fully inserted) and loosely secure using Bolts (E) with Flat Washers. **Note: fit forward Bolts (E) first due to the poor access.**
5. Loosely attach Exhaust hanger strap (D) to vehicle exhaust rubber using bolt (F) and attach to rear panel using original M10 fixing. (On twin exhaust models repeat procedure).
6. Fit neck with ZP and ZE as shown below. - **Note:** the towball height can be altered by 25mm depending on which holes have been selected (see sketch below). Fully tighten all Bolts.
7. Cut bumper as shown below. Refit bumper.

Please refer to the vehicle specification for the trailer weight and nose limits, which **must be observed**.

Recommended torque settings:, M10 - 10 Nm, M12 - 95 Nm, , M16 - 214 Nm **Grade 10.9:** M12 – 139Nm

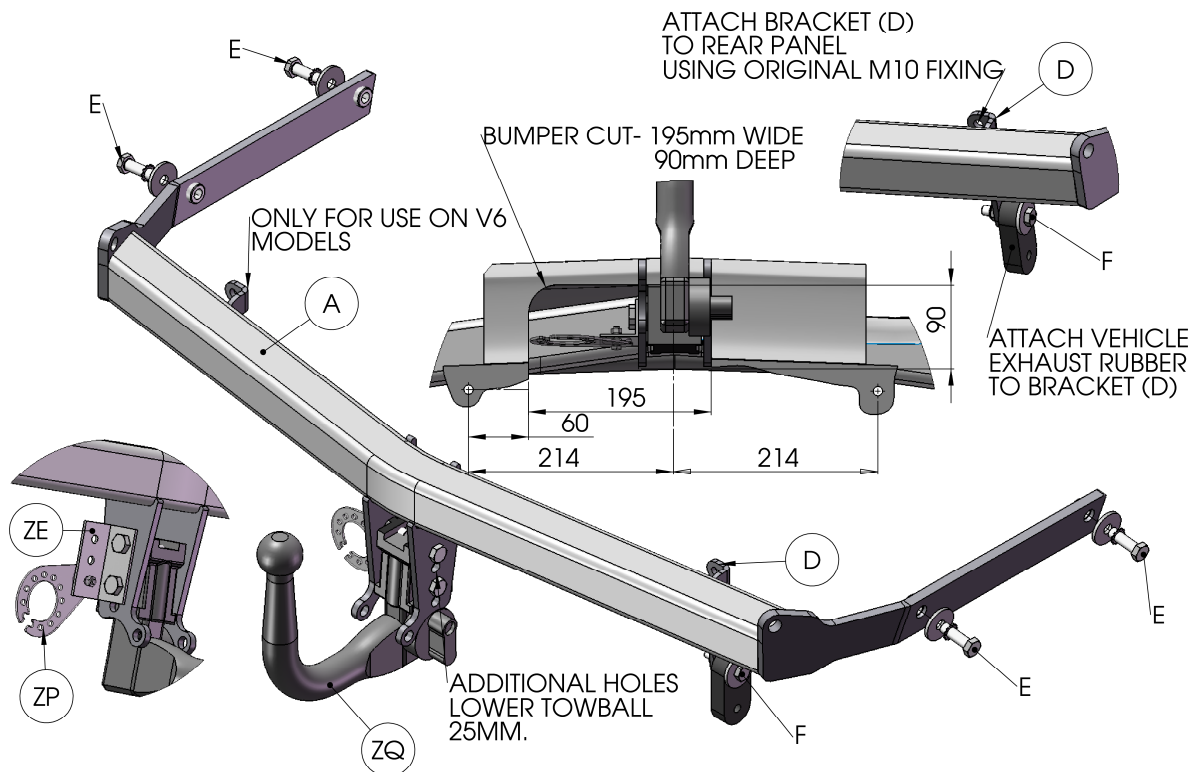

W 0001MZ48AU-FIT \$020802220000