



Fitting Instructions

TOWBAR **SU34-FIT**
For Subaru Legacy Estate **for**
2009 - **SU34 &**
SU34Q

MATERIALS

A	1	Crossbar
B	1	Right-hand Sidearm
C	1	Left-hand Sidearm
D	6	M12 x 35 x 1.75mm Bolts, Lock Washers, Large Flat Washers (30mm O.D.) and Special Nut Retainers with Square Nuts
E	4	M12 x 35 x 1.75mm Bolts, Nuts, Lock Washers and 8 off Flat Washers (25mm O.D).
F	1	Electrical Plate Mounting Bracket (ZEQ4)
ZE	1	Flip up Electrical Plate Kit (Z99)
G	2	M12 x 100 x 1.75mm Bolts and Nyloc Nuts (Grade 10.9) Supplied as part of Neck Kit.
CB	2	M16 x 50 x 2.0mm Bolts, Nuts, Lock Washers and Bolt Caps. Supplied as part of Neck Kit.
X	8	Existing M10 x 1.5 Nuts

For use with either

SU34 Flange neck option – ZF3011. **Note:** This towbar must be used with either a Witter Towball (part number Z11) or Class A50-1 or A50-X towball, which dimensionally conforms to A50-1 with a 'D' and 'S' value greater than or equal to that of the towbar.

SU34Q Detachable neck option – ZQ3011. Please refer to ZQ fitting instructions for installation

FITTING

1. Remove Bumper, 5 off plastic push clips along lower edge, 1 clip in top corner of wheel arch. Remove plastic cover to inner side of light cluster and remove the 2 off screws, pull light cluster rearward. Pull bumper tips out at top of wheel arch releasing from clips beneath light cluster.
2. Remove Crash beam and retain for re-fitting over towbar.
3. Insert cage nuts into side-arms as per diagram and insert into open ends of chassis rails. Loosely secure using fixings D
4. Re-attach crash-beam over side-arms and secure using existing fixings X. Fully tighten fixings X and then fully tighten fixings D.
5. Attach crossbar A to side-arms using fixings E.
6. Attach the required neck option with electrical plate mounting bracket F in position. Attach flip up electrical plate to bracket F.
7. Cut bumper as per diagram and re-fit.

Recommended torque settings: Grade 8.8 bolts: M8 - 24Nm, M10 - 52 Nm, M12 - 80 Nm, M14 - 130 Nm, M16 - 200 Nm
Grade 10.9: M12 – 120Nm, M10 – 70Nm M8- 35Nm



W 0001SU34U-FIT \$010802220000

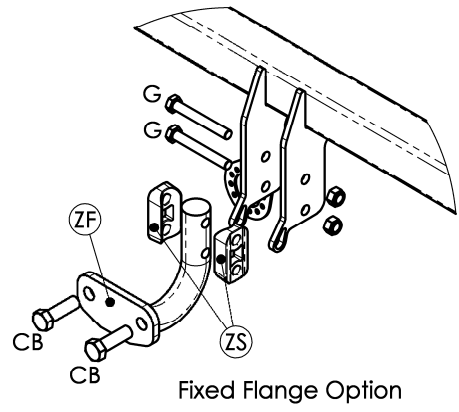
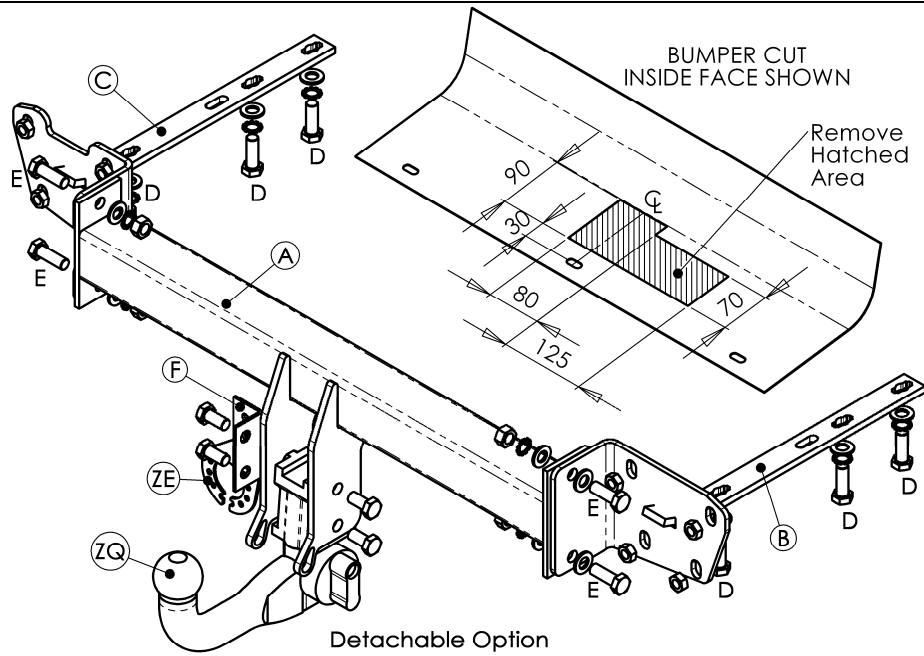

STEP 1

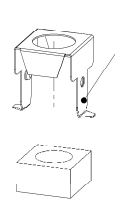

Insert nut into cage until retained by dimples.

STEP 2

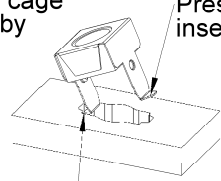

Press legs together and insert second tag

STEP 3

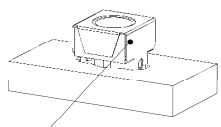

Lightly tap cage down until tags lock on opposite side.

STEP 4

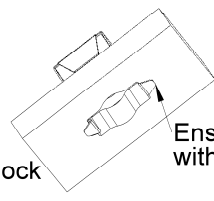

Ensure tags are flush with face