



# Fitting Instructions

TOWBAR TY104B  
For TOYOTA RAV 4  
1994-

## MATERIAL

A	1	Tubular Mainframe with 2 bolt faceplate for A50-1 type towball
C	1	Side Mounting Cleat
D	1	M12 X 30mm Bolt, Nut and Lock Washer
E	1	M12 X 30mm Bolt and Lock Washer
CB	2	M16 x 50mm Coupling Bolts, Nuts, Lock Washers
Z	1	ZEP35 Electrical plate (not shown)

## FITTING

For best appearance it is recommended that this towbar is fitted in conjunction with the Toyota rear bumper/step accessory.

### When no rear bumper is fitted:

1. Remove the towing eyes from the chassis on each side and loosely attach the Side Mounting Cleat (C) with the original bolts.
2. Attach the Mainframe (A) to the Cleat (C) on the left using Bolts (D) and (E). Attach Mainframe (A) to the chassis on the right using the original bolts.

### When Bumper is fitted:

1. On the left side, remove the long bolts (M12 X 40mm X 1.25) from the chassis and discard the 8mm thick spacing piece. Attach Cleat (C) between the left bumper arm and the chassis, using the original bolts.
2. On the right side, remove the long bolts (M12 X 40mm X 1.25) from the chassis and discard the 8mm thick spacing piece. Attach Mainframe (A) between the right bumper arm and the chassis on the right using the original bolts.
3. Attach the Mainframe (A) to Cleat (C) on the left using Bolts (D) and (E).
4. Finally tighten all bolts.

This towbar must be used with either a Witter Towball (part number Z1) or Class A50-1 or A50-X towball dimensionally conforming to A50-1 with a 'D' and 'S' value greater than or equal to that of the towbar.

Please refer to the vehicle specification for the trailer weight and nose limits, which **must be observed**.

**Recommended torque settings:** M8 - 27Nm, M10 - 53 Nm, M12 - 95 Nm, M14 - 150 Nm, M16 - 214 Nm

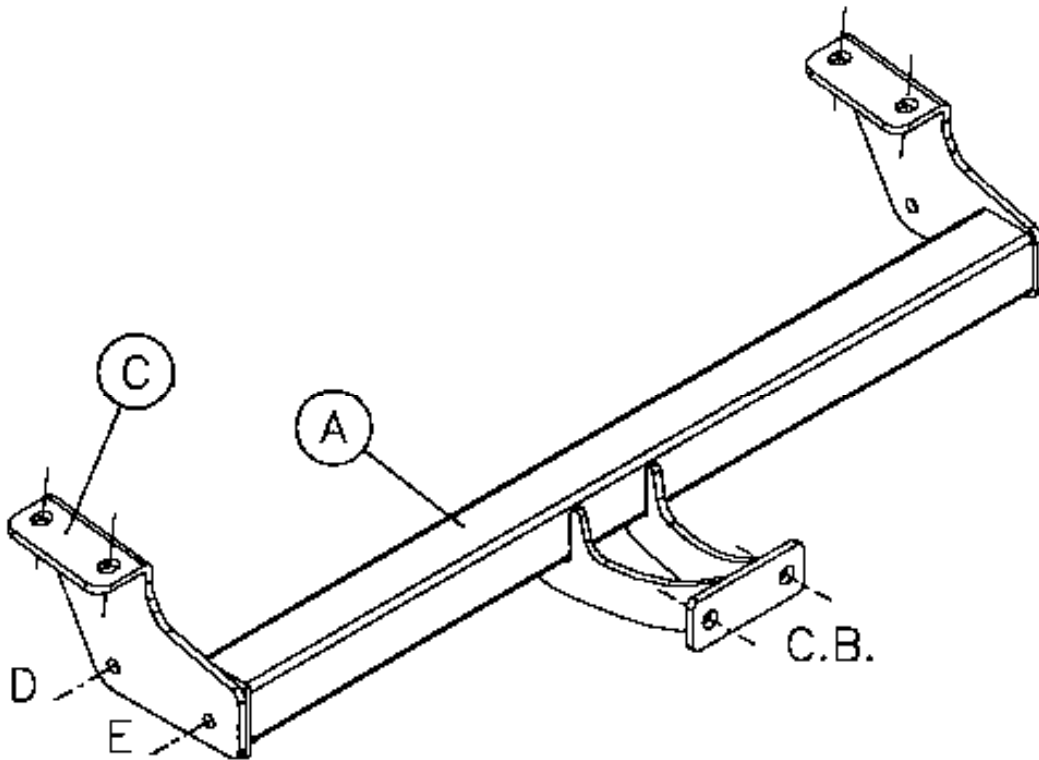

W0001TY104B-FIT\$010802220000