



Fitting Instructions

TOWBAR

For **VW93**

CRAFTER PANEL VAN / CREWBUS
single rear wheels without step – 2017 on

MATERIAL

| | | |
|----|---|---|
| A | 1 | Cross Bar |
| B | 1 | Coupling Packer |
| D | 2 | Coupling adapter plate |
| F | 8 | M12 x 110mm, Bolts, Ø40 Flat Washers and Nyloc Nuts |
| CB | 2 | M16 x 60mm Coupling Bolts, Nuts, Lock Washers |
| EP | 1 | ZEP35 Electrical plate |

Note: This towbar must be used with either a Witter Towball (part number Z11, Z32, Z46 and F40) or Class A50-1 or A50-X towball, which dimensionally conforms to A50-1 with a 'D' and 'S' value greater than or equal to that of the towbar.

Please refer to the vehicle specification for the trailer weight and nose limits, which must be observed.

FITTING

1. Remove and discard the towing eye from the right hand chassis rail.
2. Loosely attach Cross bar (A) to existing bushed holes in vehicle chassis using Bolts F with Flat Washers and Nyloc nuts.
3. Torque all bolts to values listed below.
4. Use Coupling adapter plate (D) on forward face when attaching coupling.

Recommended torque settings: Grade 8.8 bolts: M16 - 200 Nm.
Grade 10.9 bolts: M12 - 130 Nm

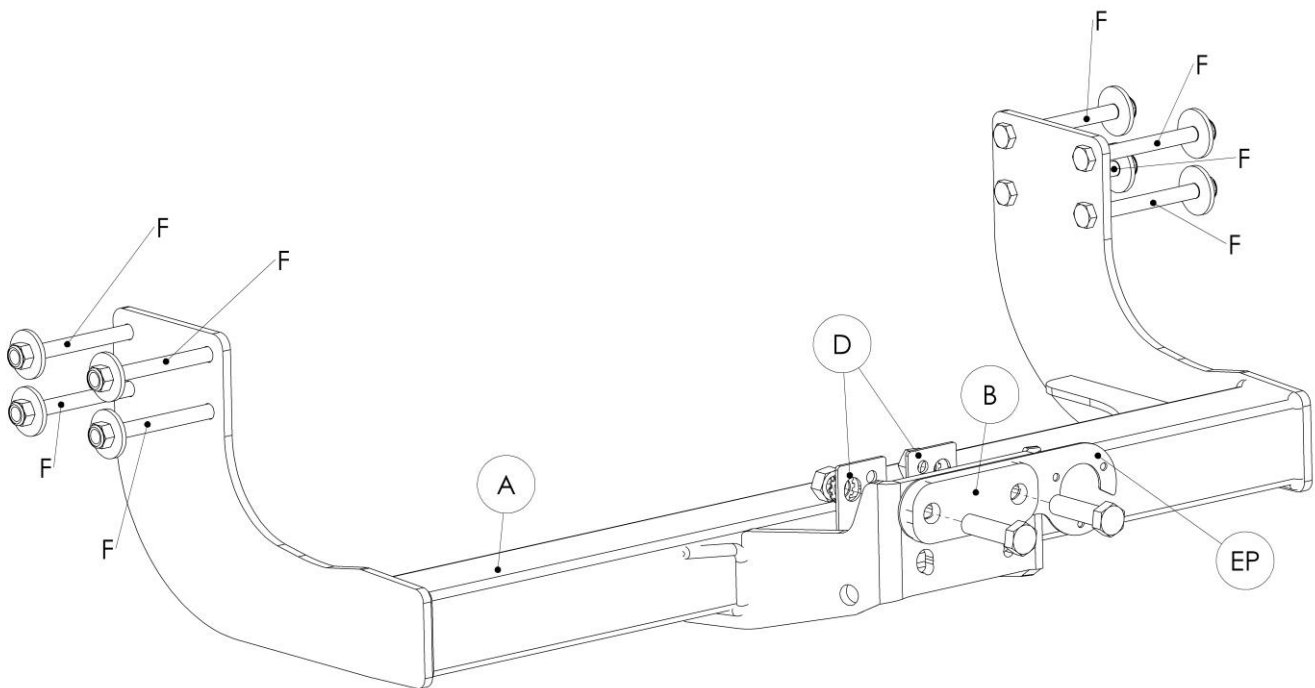

W 0001VW 93-FIT\$021004060000



Notice de Montage

Attelage pour

r **VW93**

CRAFTER Fourgon / CREWBUS

Roue simple sans marchepieds

2017-

MATERIAL

| | | |
|----|---|---|
| A | 1 | Traverse principale |
| B | 1 | Entretoise d'accouplement |
| D | 2 | Adaptateur d'entretoise d'accouplement |
| E | 8 | Boulons M12 x 110mm, rondelles plates Ø40 et écrous Nylocs |
| CB | 2 | Boulons d'accouplement M16 x 60mm, écrous et rondelles freins |
| EP | 1 | Plaque de support de prise ZEP35 |

Remarque : cet attelage doit être utilisée avec une boule de remorquage Classe A50-1 ou A50-X se conformant dimensionnellement à A50-1 avec une valeur 'D' et 'S' supérieure ou égale à celle de la barre de remorquage.

Veillez-vous reporter aux données techniques du véhicule pour les limites de masse et du poids tractable admis sur la boule, lesquelles sont à observer.

Installation

1. Enlever l'anneau de remorquage et le remettre au client.
2. Sans serrer, attacher la traverse principale (A) aux points de fixation de l'attelage à l'aide de la visserie E.
3. Serrer toutes la visserie au couple de serrage recommandé.

Couple de serrage recommandé: Visserie de Classe8.8: M16 - 200 Nm.
 Classe 10.9 bolts: M12 - 130 Nm

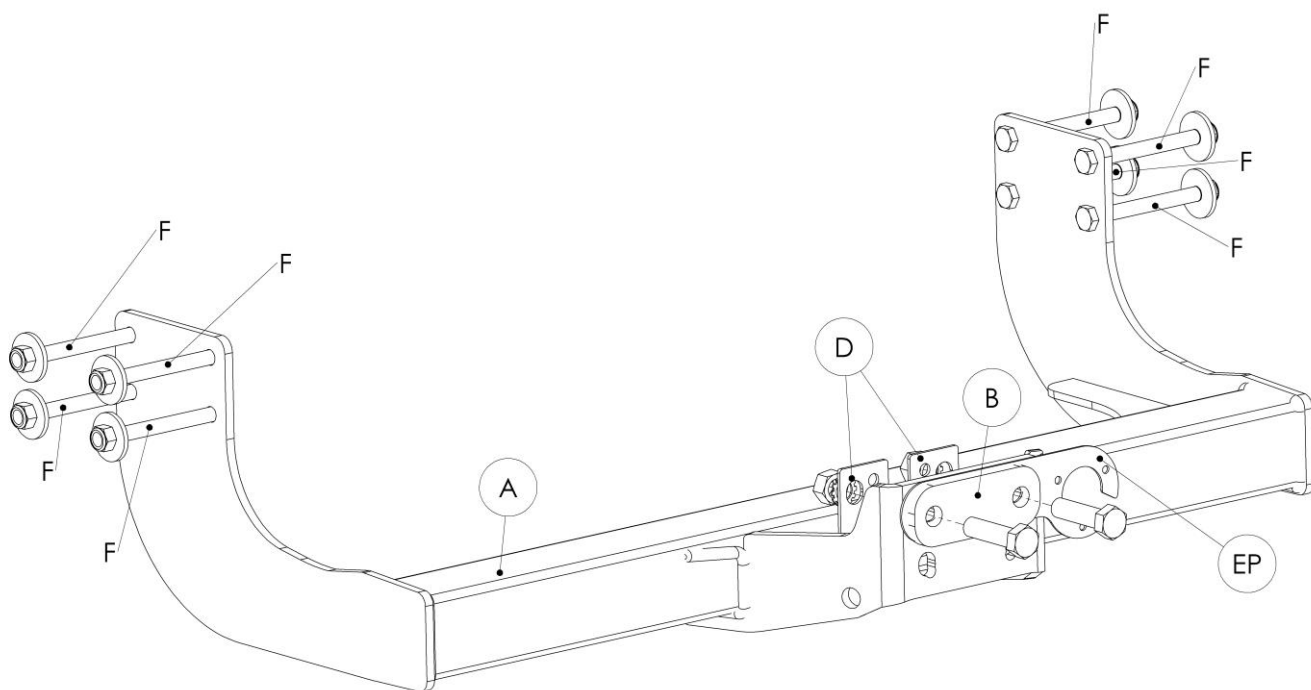

W0001MR35B-FIT\$020908120000